

Model #

2404AFGAC; 2404AFCAF

McKenzie Lateral File Hutch

AFGAC = Glazed Antique Cherry finish

AFCAF = Caffè finish

Assembly Instructions

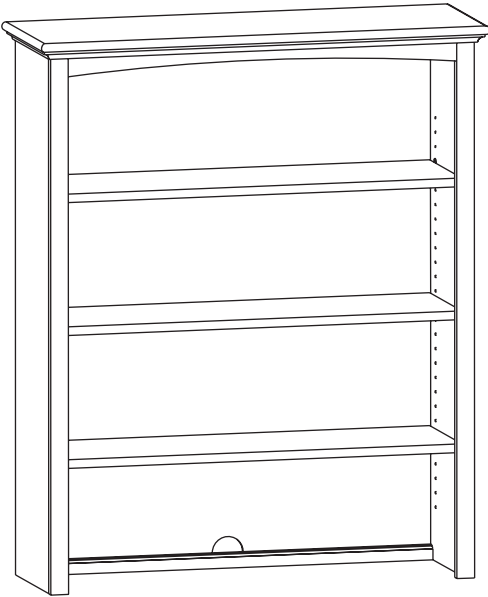

Congratulations!

This fine piece of furniture will make a gorgeous addition to your home. For the best results, read the Assembly Instructions before you begin your project.

! IMPORTANT NOTES:

- For normal household use only. **Not** recommended for commercial use.
- Do not climb, sit or stand on this unit.
- Do not overload the shelves on this unit.
- Unload items before you move this unit.
- Before you load or move this item, tighten all screws and supports.
- Before you begin your project, completely read the Assembly Instructions.
- Store this item: 1- in its box; 2- in a dry place; 3- in temperatures that range from 40°F to 90°F (not on a cold and possibly damp cement floor).
- Periodically inspect your furniture for any loose glue joints, screws or any other problem that might affect the stability of your furniture. Tighten or repair as needed.

DESIGN SUBJECT TO CHANGE WITHOUT NOTICE.



CALL US FIRST! *Do not return this item to the store.*

Service Policy: We will replace any part that is defective, missing or damaged during assembly. For a replacement part, contact Whittier Wood Products customer service department by phone, fax, mail or email.

Hours: Our friendly customer service staff can be reached Monday-Friday 7:00 a.m. to 5:00 p.m. (Pacific Time). You may leave a message 24 hours a day, seven days a week.

To Order: Provide the finish and furniture model number (upper portion of this page), the part letter, production code, quantity needed, reason for replacement and your full name, address and telephone number.

Parts ship from our Eugene, Oregon factory within one or two business days from the time we receive your request. Please allow five to ten business days for delivery.

800-653-3336 • Outside the U.S. or Canada: 541-687-0213 • Fax: 541-687-2060
www.whittierwood.com • P.O. Box 2827 • Eugene, Oregon 97402, U.S.A.

**Whittier
Wood**
FURNITURE

P.O. Box 2827
Eugene, OR 97402 USA











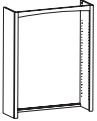

Production Code:

VN

02/11

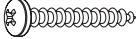
2404AFGAC; 2404AFCAF McKenzie Lateral File Hutch — Parts List

Please identify the parts and check that quantities received match those on this list.
If you need to replace a part, refer to the following letter and model name.

Part	Description		Quantity
A	Case Assembly		1
B	Top Assembly (attached)		1
C	Back (attached)		1
D	Adjustable Shelf (attached)		2
E	Bottom Shelf (attached)		1
F	Shelf Bracket (attached)		8
G	#6 x 1/2" Undercut Screw (inserted)		8
H	#6 x 5/8" Philtruss Screw (inserted)		26 (18 inserted)
I	Steel Brace		2
J	#8 x 1-1/4" Pan Head Screw (inserted)		4
K	Pad Strip (attached)		2
L	Rafix Cam (inserted)		4
M	Rafix Bolt (inserted)		4
N	#8 x 1-5/8" Black Screw (inserted)		7
TR	Tipping Restraint		2 sets

2404AFGAC; 2404AFCAF McKenzie Lateral File Hutch Assembly Instructions

Tool Required: Phillips Screwdriver

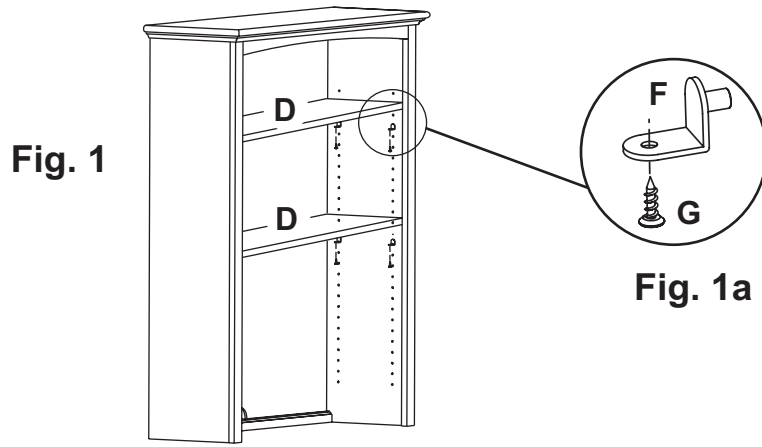

1. To move the Adjustable Shelves (D), remove the #6 x 1/2" Undercut Screws (G) and the Shelves (D). Reposition the Shelf Brackets (F), replace the shelf and insert the screws. See Figures 1 and 1a.
-

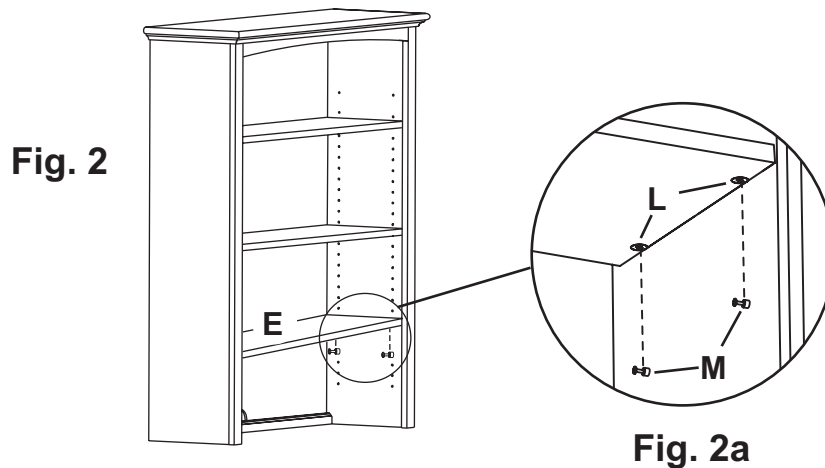

READ THE RAFIX ATTACHMENT SYSTEM INSTRUCTIONS NOW

2. To move the Bottom Shelf (E), loosen the Rafix Cams (L) and remove the Shelf (E). Reposition the Rafix Bolts (M), replace the shelf and settle the Rafix Cams (L) over the Bolts. Tighten the Rafix Cams. See Figures 2 and 2a.

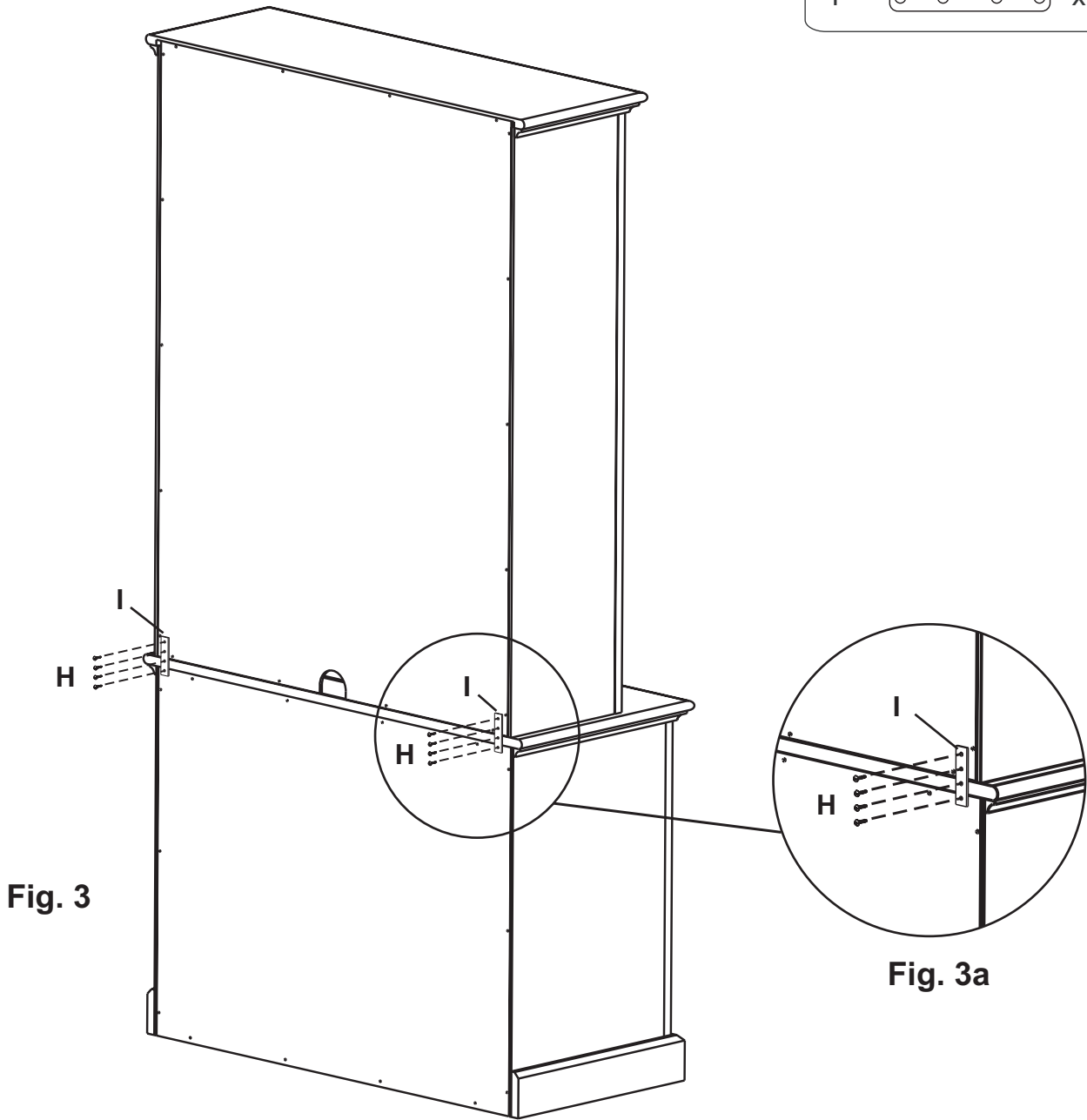
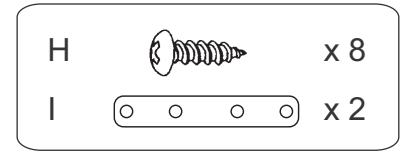

- Secure the Hutch to the McKenzie Lateral File by attaching two Steel Braces (I) with eight #6 x 5/8" Philtruss Screws (H) as shown in Figures 3 and 3a.

Note: The 2404 Hutch is designed to use *only* with the 2403 Lateral File Cabinet. It is imperative to properly install the tipping restraints to the File Cabinet.

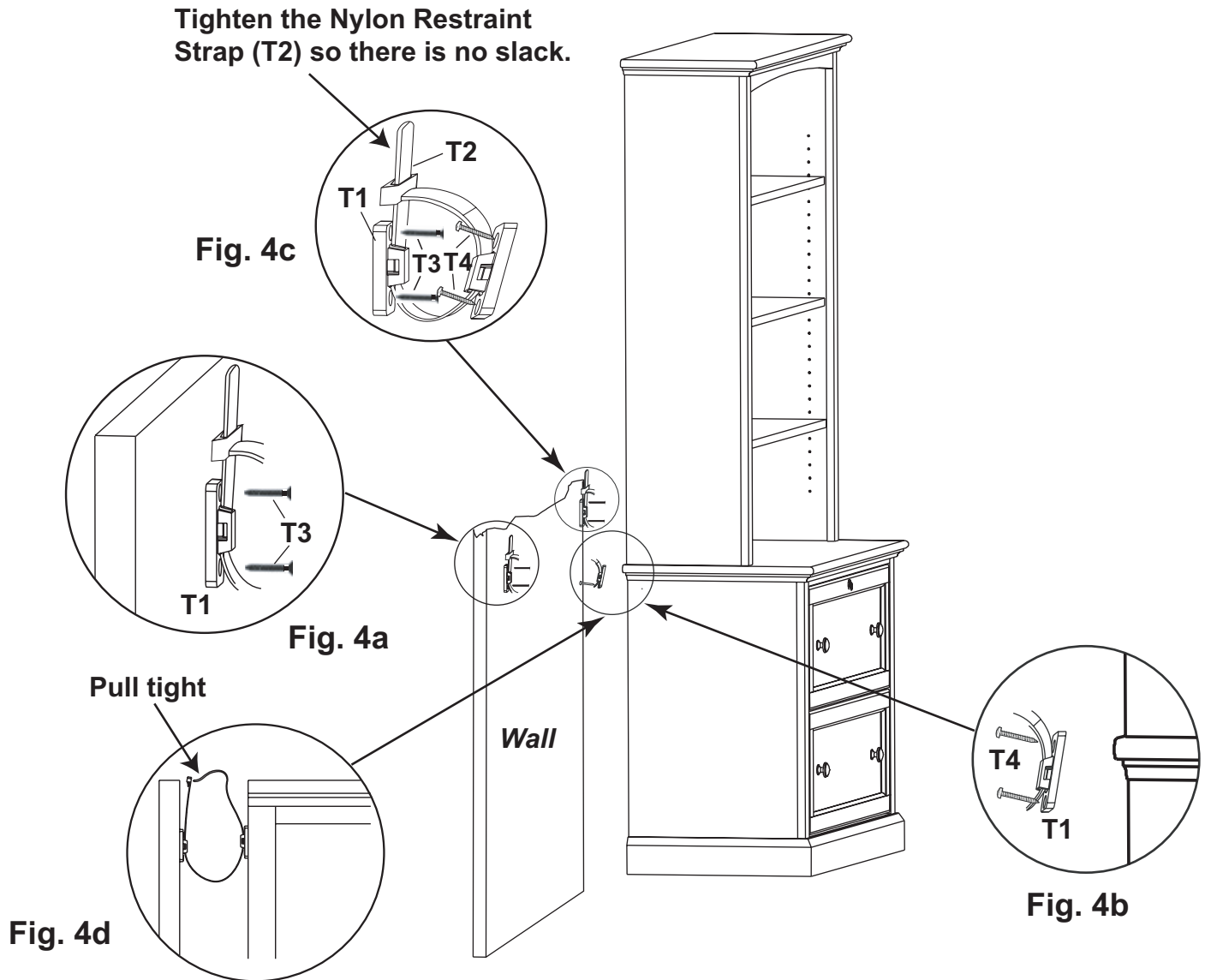

4. Locate two studs in the wall behind the unit. Attach a Clip (T1) to the wall stud with two #8 x 2" Black Screws (T3). See Figure 4a. Attach a second clip to the unit with two #8 x 1" Pan Head Screws (T4). See Figure 4b. Connect the two clips with the Nylon Restraint Strap (T2). **Pull the Nylon Restraint Strap (T2) tight so there is no slack.** See Figures 4c and 4d. Repeat this procedure to attach the second tipping restraint. If you cannot locate two studs, purchase the proper wall attachment hardware for your type of wall and secure the unit.

RAFIX ATTACHMENT SYSTEM

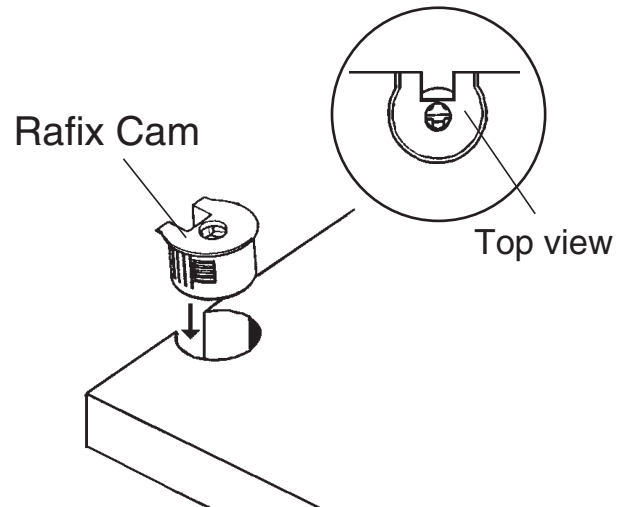
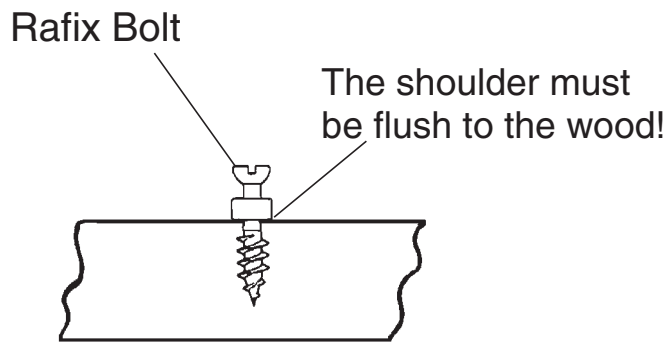

1. Insert the Rafx Bolt into the shelf so that the shoulder is flush to the surface of the wood.

2. Tap a Rafx Cam into the appropriate hole. Face the notch to the edge of the shelf. The flat edge of the cam must be parallel to the front edge of the shelf.

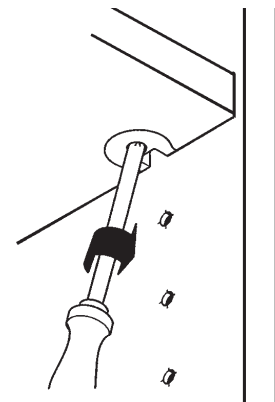
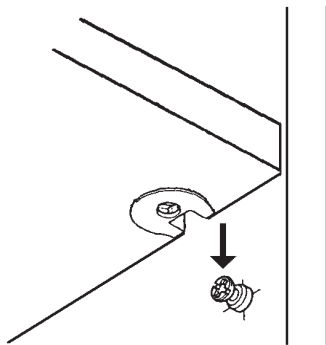

Position the screwdriver at a 25° angle.

3. Slide the Rafx Cam over the Rafx Bolt.

4. Using a Phillips Screwdriver at a 25° angle, tighten the Cam about a half turn.